

REFRIGERATION UNDERBENCH

FT-1500R | FT-1500F

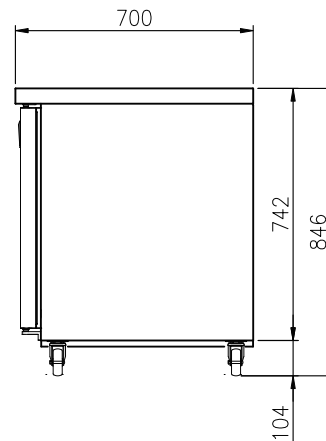
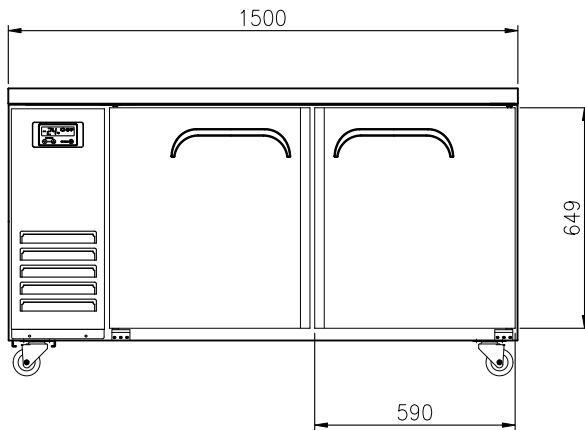
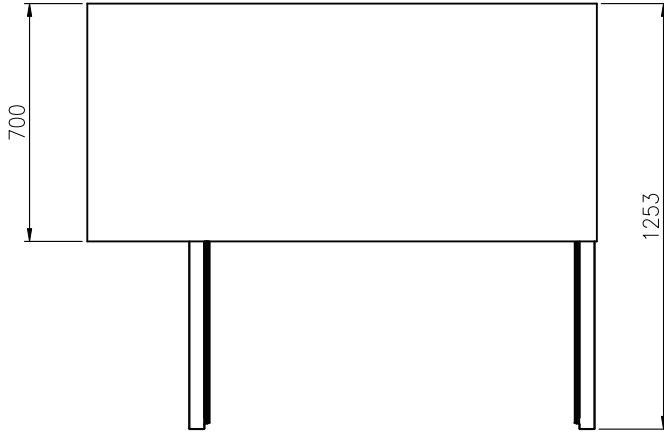

FEATURES

- Digital temperature control & monitor system
- 3" casters (brakes at front)
- Fully stainless steel finished cabinet
- PE coated sturdy wire shelves
- Auto-closing doors & stopper
- Door pressure release device
- Magnetic door gasket

TEMPERATURE

- Fridge: 0°C ~ 5°C
- Freezer: -18°C

OPTIONAL MODELS

- Leg model
- 4" or 5" casters

Model	Capacity (ℓ)	Exterior Dimension (mm)			Net Weight (kg)	Gross Weight (kg)	Power Supply	Amps	Voltage (V/Hz/Ø)	Watt	HP	Refrigerant	No. Doors
		W	D	H									
FT-1500R	402	1,500	700	846	84	94	10A	2.0	240/50/1	340	1/3	R-134a	2
FT-1500F	342	1,500	700	846	87	97	10A	3.0	240/50/1	380(D:520)	3/8	R-134a	2

* The heights include the caster (104mm) * D: Defrost
 * Design and specifications subject to change without notice
 * Actual shipping weight may differ due to extra packing materials for product protection.