

USER MANUAL

TOP MOUNT UPRIGHT

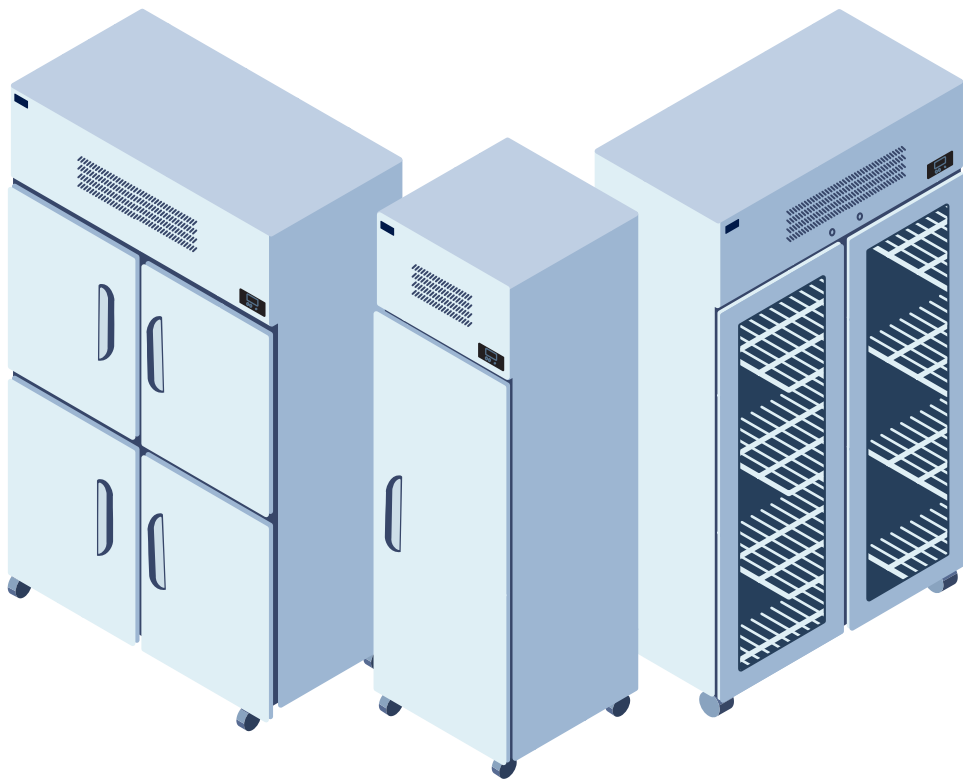

UPRIGHT

Top Mount Upright

KTM-25RS1, KTM-25FS1 | KTM-25RS2, KTM-25FS2 |
KTM-45RS2, KTM-45FS2 | KTM-45RS4, KTM-45FS4

Glass Door Top Mount Upright

KTM-25RG1, KTM-25FG1 | KTM-45RG2, KTM-45FG2

※ Please read this manual completely
before attempting to install or operate this equipment



<https://fresh-refrigeration.com.au>

SAFETY PRECAUTIONS

To avoid any risk of fire, explosion, electric shock, personal injury, material damage or incorrect use of the appliance, always observe the following safety precautions. Read the owner's manual instructions and retain them in safe place for future.



- 1** Ensure the unit must be installed and located in accordance with the manufacturer's installation
- 2** Ensure the unit is disconnected from the power supply before any maintenance and cleaning
- 3** Ensure the unit has adequate ventilation; do not cover the grill and/or block the entry or exhaust of airflow by stocking objects against the unit
- 4** Do not allow children to climb, stand or hang on the unit including doors, and shelves. This may not only damage the unit, but also occur the serious injury to the children
- 5** Handle with care in order to avoid any serious damage to the refrigerant
- 6** The unit contains the flammable refrigerant which may have risk of fire or explosion

INSPECTION

Upon receipt of the unit, all items should be carefully inspected against the Bill of lading to ensure all packages (carton or/and pallet) have been received correctly. Do not sign the freight document until properly inspected, including concealed damage. If any damage is found, it should be reported to the carrier at once, noted on the Bill of Lading followed with a claim to the carrier. As all equipment has been inspected and tested on site at our manufacturing facility, FRESH Refrigeration is NOT RESPONSIBLE for freight loss or damages.

INSTALLATION

Before Installation

- Remove all the packages, protections and coverage before installation.
- Clean the interior and exterior such as drawers, doors worktop surfaces of the unit with a stainless steel safe and suitable solution.



Do not use chlorinated cleaners on the surfaces as they can cause corrosion and/or rust.

Ventilation

- The unit must be met all ventilation requirements below; The compressor system requires air flow access for proper operation.

- Clearance :

- 1) Allow a minimum of 7.5mm of clearance from the rear side.
- 2) Allow a minimum of 300 mm of clearance from the top.

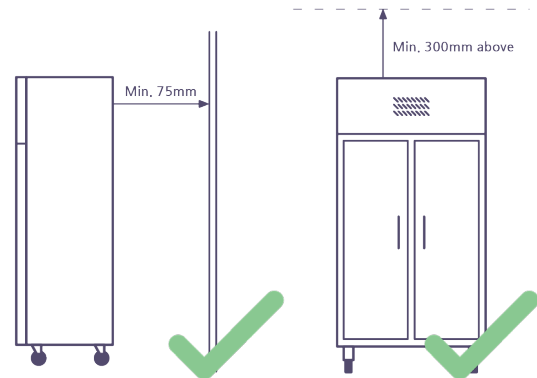

Location

The unit levels from the front to the back and side to side



The installation surface must be capable of supporting the load of the cabinet.

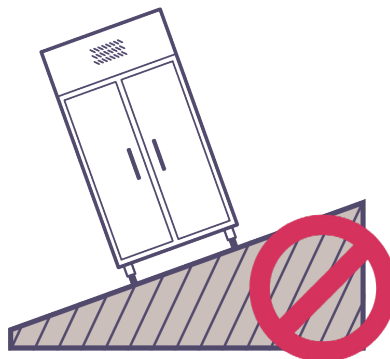

The unit must be installed on an even surface; uneven or tilted surface can make noise or/and poor performance.

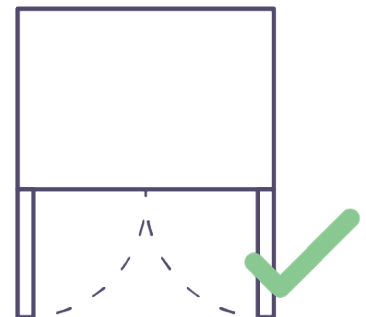

Give enough space side and front to open the door

Ambient Temperature

The unit is intended to install indoors only to avoid extreme temperature and humid

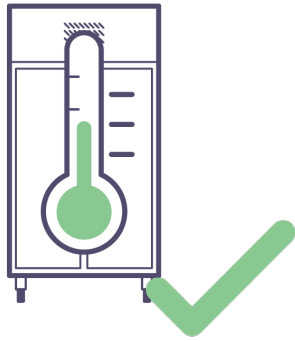

The unit must be installed in an environment within its climate class. (30 °C , Humidity : 55%)

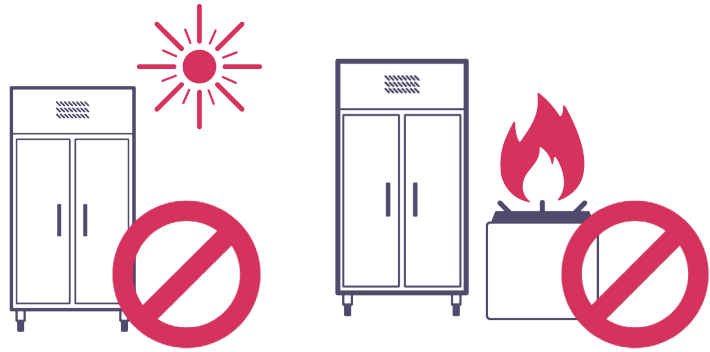

Do not place the unit in an area next to heat generating equipment or with direct sunlight.

Electricity

- Confirm that the proposed electrical outlet has the correct voltage, frequency and current carrying capacity for the requirements of the unit. This information is noted on the data plate on the inside left wall of the unit. The unit should be isolated on a circuit.
- If the unit is not used for long period, UNPLUG it from the power supply (socket).
- After unplugging, wait at least 5 minutes before plug back in. Abnormal operation in power can damage the unit.
- The electrical plug must be accessible without moving units.



The unit should be on dedicated outlet; do not overload

DO NOT use an extension cord to get power to the unit. Improper electrical installations will void the compressor warranty. To prevent shock and fire, be sure the unit is properly grounded.

Adjustment & Assembling

- If the door(s) have come out of alignment during shipping they will need to be adjusted: opening the door(s) and loosening the screws that hold both the top and bottom hinges to the cabinet. After adjusting the door so it is aligned correct, tighten the screws to securely hold the hinges and door(s) in place.
- Install the shelf clips on the pilaster and set the shelves on top of the clips. The shelves and self clips are packaged inside the unit. The shelves are adjustable in ½” increments. One shelf can support up to 40kg.
- The temperature controller is located on the upper right side of the exterior. A default temperature has been set from our factory. Adjust the temperature to fit your needs.

USAGE

Temperature

- This unit is NOT for Chilling nor Freezing. Please cool down the hot/warm food or product before storing
- Cool down the unit until achieving the desired temperature before loading product or food



Notice

You must run the unit for 24 hours prior to usage to achieve desired interior temperature

Loading



Do not store too much product or food in the unit until the item fall out when you open the door. (Do not overhang)

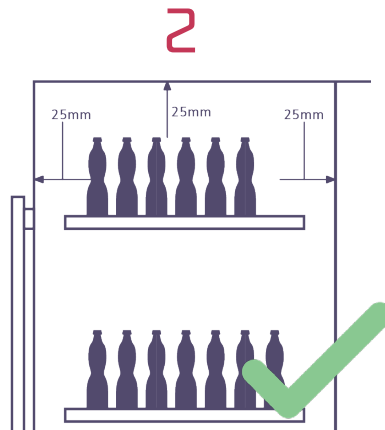

Give 25mm room between back, top and side of the interior cabinet



One shelf can support up to 40kg; DO NOT overload the shelves

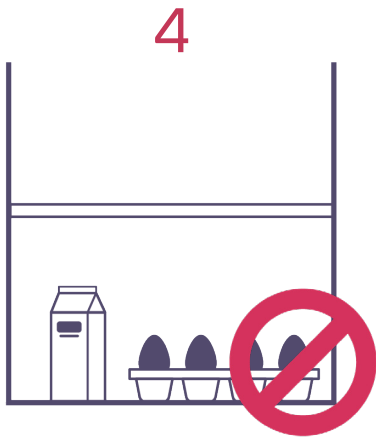

Do not store the product on the floor



When stocking items in the cabinet with content, be sure not block the fan; blocking the air flow may decrease performance.

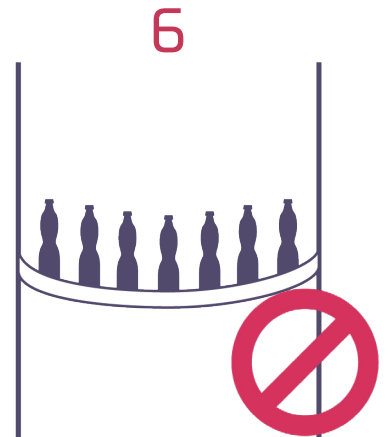

Do not load the product if the shelf is flexing or bending

Ventilation

Do not store objects (e.g. boxes) in front or on top of the cabinet which will block the grill and/or block the entry or exhaust of airflow



MAINTENANCE

Interior and Exterior Cleaning

- The interior surfaces of the cabinet should be periodically cleaned with a food safe solution such as water and baking soda. All stainless-steel surfaces should be cleaned with commercially approved solutions.
- Do not use chlorinated cleaners on the stainless-steel surfaces.
- Do not use stainless steel cleaners or other solvent-based chemicals on the plastic parts (door handle or trim strips) as they can cause corrosion. Use mild soap and warm water on plastic parts.
- The door gaskets should be wiped down periodically with a mild soap solution to extend their life.
- The shelving can be cleaned in a sink with a mild soap solution and a soft bristled brush.

Condenser Coil Cleaning

- It is recommended to check and/or clean this area a minimum of 4 times a year, once quarterly.
- Periodic cleaning of the condenser coil is necessary to help the refrigeration system and increase its efficiency.

steps

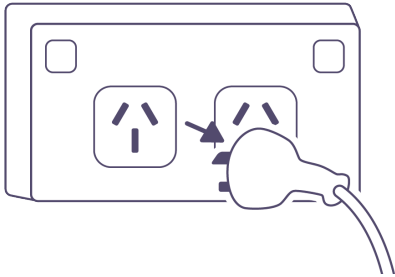

1 Disconnect the power before cleaning the condenser coils.

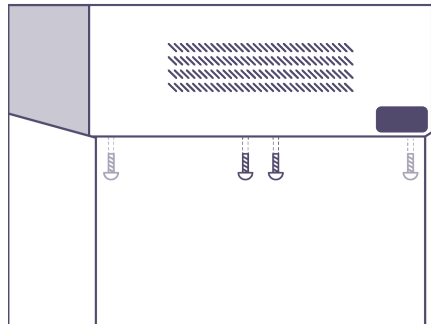

2 Unscrew the bolts (2 or 4 of them) underneath of front grill and lift it. The condenser coil is located behind the grill.

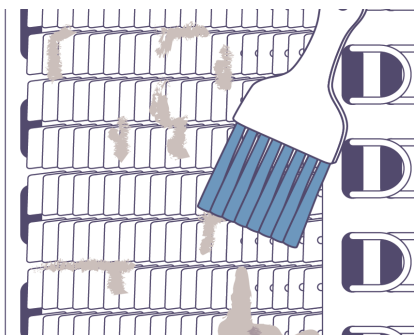
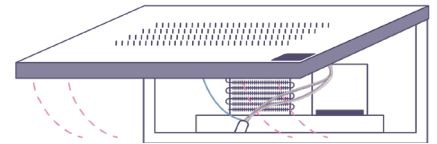

3 Use a soft bristled brush to remove any dirt particles that are on the fins of the condenser coil. A vacuum cleaner maybe used along with compressed air to remove the loosened particles.

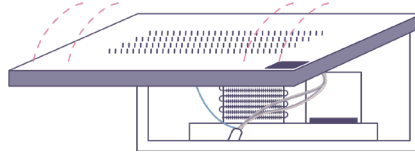

4 Reassemble the grill and reconnect the unit to power

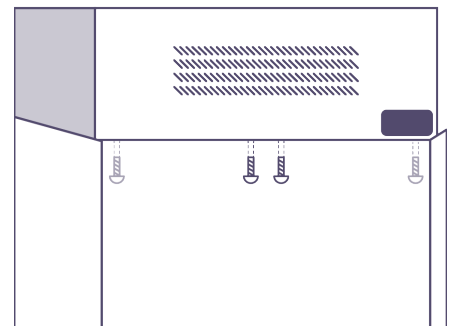

Failure to clean the condenser coils may lead to performance loss and compressor failure.

SPECIFICATIONS

Product		TOP MOUNT UPRIGHT			
		FRIDGE		FREEZER	
Model		KTM-25RS1 KTM-25RS2 KTM-25RG1	KTM-45RS2 KTM-45RS4 KTM-45RG2	KTM-25FS1 KTM-25FS2 * KTM-25FG1	KTM-45FS2 KTM-45FS4 * KTM-45FG2
Capacity (ℓ)		480	1034	480	1034
Exterior Dimensions (mm)	W	653	1280	653	1280
	D	801			
	H	1934			
Net Weight (kg)		102 103	153 155	104 105	163 165
Electrical Characteristics		220~240V / 50Hz / 1Ph			
Amps		3.2	4.0	4.0 * 6.0	6.0 * 7.5
Plug Range		10A			
Condensing Unit Size		3/8 HP	3/8 HP	3/8 HP	3/4 HP
Refrigerant		R-134a	R-134a	R-134a * R-404a	R-404a * R-404a
Temperature Range		0 °C ~ 10°C		-22 °C ~ -10°C	
Shelves		3EA	6EA	3EA	6EA
Doors		1 / 2	2 / 4	1 / 2	2 / 4

- Above specifications are subjected to change without prior notice for quality improvement.
- The height includes 3-inch casters. 4- or 5-inch casters are available

OPERATION

Basic Operation

- 1 Plug in and the unit is automatically turned on. The display panel will be lighted with beep sound and begin its operation after 5 seconds. The compressor will begin to run.
- 2 The default temperature setting is 4 ° C for fridges and -18 ° C for freezers.
- 3 The compressor and defrost cycle are automatically programmed by the electronic controller (PCB).
- 4 The fridge will defrost for few minutes every 6 hours, and when it is defrosting you will see the “dF” indicator turned on, on the screen ; The freezer will defrost randomly every 6 hours to 14 hours depending on the compressor running
- 5 When the door opens, the interior light is automatically activated and the evaporator fan motor stops. * The light for glass door model is operated by switch.
- 6 Evaporator fan motor(s) will run after all doors are completely closed.

 **Notice** Good Air Flow in Freezer unit is critical. (Be careful to load product so that it neither presses against the back wall, reaches within for inches from the evaporator compartment.)

DISPLAY PANEL

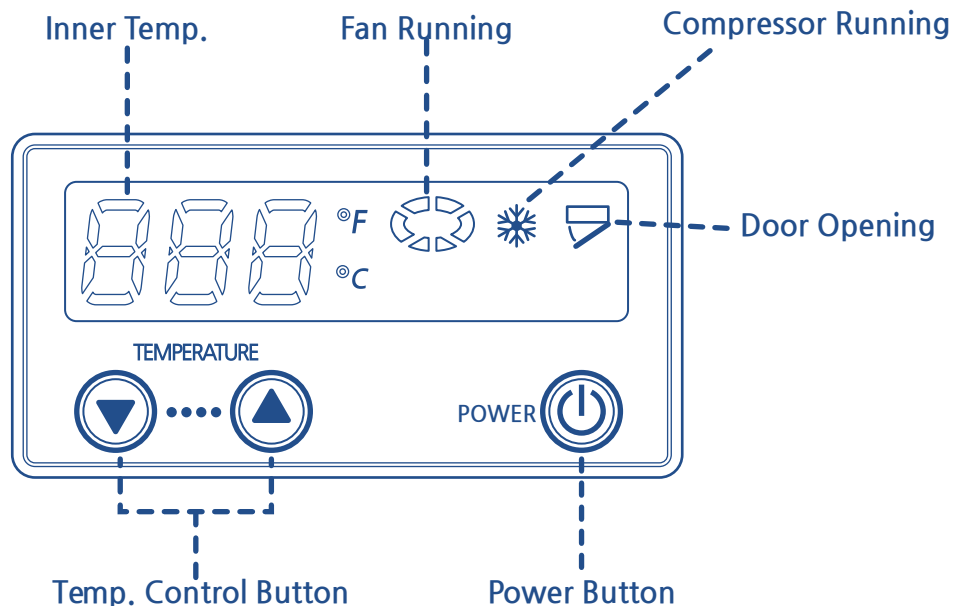

Power Button

- Use the button  to Turn ON & OFF
- Press the power button for 3 seconds to turn on/off
- This power button is only for temporarily turn off.

 **Caution** DO NOT turn off for long time with the power button only. UNPLUG it from the power socket.

Temperature Control Button

- Use the button  to change the temperature.
- By pushing the up / down button, you can set the cabinet inner temperature.
- Leave it without any further operation for 3 seconds, the temperature setting is done, and the lamp will turn off.
- Every time you press the button, temperature changes by 1°C
- The temperature range for fridge: 1~10°C and for Freezer : -22~ -10°C

Fan Running Indicator

- If the fan motor is running, fan running indicator is on.
- When the door opens, the evaporator fan motor stops, and the indicator is on.
- When the door is closed, the evaporator fan motor starts, and the indicator is off.

Door Opening Indicator

- If door is opened, the door opening indicator will be turned on.
- When the door opens more than 30 seconds, It beeps 3 times.
- When the door opens more than 1 minutes, It beeps 5 times.
- When the door opens more than 5 minutes, It beeps continuously.
- The beep sound will stop immediately upon closing the door.

CALL FOR SERVICE

- 1 Before contacting our Service Department, please review this manual carefully again and follow the trouble shooting below



Warning

WITHOUT reading this book and lodging the service may occur service fee

- 2 Restart the appliance to check whether the fault repeats. If the malfunction persists, switch off the appliance and try again after an hour.

- 3 If the malfunction persists, then contact our Customer Service, specifying:

- ▶ The nature of the problem (as detail as possible)
- ▶ The appliance model number and serial number (located the left or right interior wall)
- ▶ Your full address, contact number and name

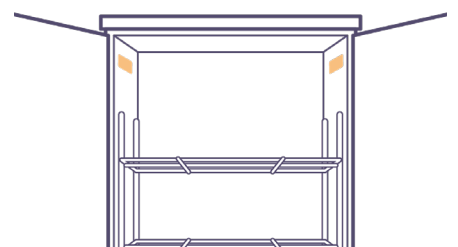

TROUBLE SHOOTING

Symptom	Causes	Solutions
Compressor does not start	<ul style="list-style-type: none"> • No power • Not enough electricity 	<ul style="list-style-type: none"> • Check the power cord and make sure it is plugged in • Check the power cord uses one dedicated outlet from power socket • Check it is not connected to extension cord.
Unusual Noise	<ul style="list-style-type: none"> • The floor is too weak • The unit is not levelled • Screws or parts are loosened • Fan blades are touching surrounding parts • No ventilation (heat goes back to the machinery part) 	<ul style="list-style-type: none"> • Check the installed location • Check for loose part or mounting. • Keep the tubing free from any contact to avoid rattle. • Check fan blades to see if they are contacting anything. • Maintain 7.5mm of clearance from the wall.
Not enough cooling	<ul style="list-style-type: none"> • Unit is installed in unsuitable location • Incorrect temperature setting • Not enough ventilation • The stored product is overloaded internally • The stored product is too hot • The condenser is clogged • Door opens 	<ul style="list-style-type: none"> • Move the unit from direct sunlight or away from heat generating devices • Adjust the temperature setting to a lower temperature. • Install the unit in a well-ventilated area, with at least 7.5 mm of clearance from all sides. • Remove the boxes and obstacles away from the unit ventilation • Clear contents/product from blocking the air duct in the interior. • Reduce stored product that make room inside • Clean the condenser if there is dust. • Check the door and be sure it is completely closed.
Too much cooling Food is freezing	<ul style="list-style-type: none"> • The temperature set too cold 	<ul style="list-style-type: none"> • Adjust the temperature setting to a higher temperature
Dewdrops on the exterior of the unit	<ul style="list-style-type: none"> • Too much humidity or high moisture in the air 	<ul style="list-style-type: none"> • Reduce humidity where the unit is installed.
Dewdrops on the interior of the unit	<ul style="list-style-type: none"> • The humidity goes inside the cabinet • Water from stored food 	<ul style="list-style-type: none"> • Repair or replace the gasket on the door • Keep the door closed • Remove the damp food
Door is not closed tightly	<ul style="list-style-type: none"> • Unit is not levelled • Door gasket is worn or torn • Door is not levelled 	<ul style="list-style-type: none"> • Level the unit • Replace the door gasket • Unscrew and reposition the door



The Following points are not malfunctions:

- ▶ Water-Flowing sound when the compressor stops : this sound is refrigerant flowing
- ▶ The compressor stops when defrost cycle

WARRANTY INFORMATION

Limitations

Fresh Refrigeration's sole obligation under this warranty is limited to either repair or replacement of parts, subject to the additional limitations below. This warranty neither assumes nor authorizes any person to assume obligations other than those expressly covered by this warranty.

- 1 NO CONSEQUENTIAL DAMAGES. FRESH REFRIGERATION IS NOT RESPONSIBLE FOR ECONOMIC LOSS; PROFIT LOSS; OR SPECIAL, INDIRECT, OR CONSEQUENTIAL DAMAGES, INCLUDING WITHOUT LIMITATION, LOSSES, OR DAMAGES ARISING FROM FOOD OR PRODUCT SPOILAGE REGARDLESS OF WHETHER OR NOT THEY RESULT FROM REFRIGERATION FAILURE.
- 2 WARRANTY IS NOT TRANSFERABLE. This warranty is not assignable and applies only in favour of the original purchaser/user to whom delivered. ANY SUCH ASSIGNMENT OR TRANSFER SHALL VOID THE WARRANTIES HEREIN AND SHALL VOID ALL WARRANTIES, EXPRESS OR IMPLIED, INCLUDING ANY WARRANTY OF MERCHANTABILITY OR LABOR COVERAGE FOR COMPONENT FAILURE OR OTHER THE WARRANTY PACKET PROVIDED WITH THE UNIT.
- 3 Fresh Refrigeration will not be held responsible for the following external factors: ALTERATION, NEGLIGENCE, ABUSE, MISUSE, ACCIDENT, DAMAGE DURING TRANSIT OR INSTALLATION, FIRE, FLOOD, ACTS OF GOD, OR IMPROPER ELECTRICAL CONNECTIONS.
- 4 FRESH REFRIGERATION IS NOT RESPONSIBLE FOR THE REPAIR OR REPLACEMENT OF FAILED OR DAMAGED COMPONENTS RESULTING FROM ELECTRICAL POWER FAILURE, THE USE OF EXTENSION CORDS, LOW VOLTAGE, OR VOLTAGE DROPS TO THE UNIT.
- 5 Use of THIRD PARTY parts without FRESH Refrigeration's approval may void warranty.
- 6 NO IMPLIED WARRANTY OF MERCHANTABILITY OR FITNESS FOR A PARTICULAR PURPOSE; THE FOREGOING WARRANTIES ARE EXCLUSIVE AND EXPRESSLY GIVEN IN LIEU OF ALL OTHER WARRANTIES, EXPRESSED, IMPLIED OR STATUTORY. THERE ARE NO WARRANTIES, WHICH EXTEND BEYOND THE DESCRIPTION ON THE FACE HERE OF.
- 7 Any warranty provided under or in connection with this Agreement relates only to Goods manufactured and supplied by us. The warranty excludes:
 - (a) Replacement or repairs which are required as a result of improper installation, misuse, maladjustment, modification or lack of routine maintenance by others;
 - (b) Items subject to deterioration or consumption in normal service (such as lamps, bulbs, fuses, batteries);
 - (c) Goods, materials or parts supplied or manufactured by unrelated third parties and provided to you at your specific request and such goods, materials or parts will be repaired or replaced only to the extent of the original supplier's warranty; and
 - (d) all other terms, conditions, and warranties or guarantees implied or imposed by statute, common law or otherwise in relation to the Goods are hereby excluded, except to the extent otherwise provided by law.

Warranty for Goods (from T&C)

12.2.1 Unless otherwise stated in our quotation or agreed by us at the time of acceptance of your offer, subject to 12.4.2, the warranty period for the supply of goods shall be one year from the date of manufacture of the goods (Goods Warranty Period).

12.2.2 We warrant that the goods will on their delivery to you conform with the description in this Agreement or such description agreed by us in writing at the time of acceptance of your offer or as amended in accordance with clause 5 and that there will be no defects in material or fault in manufacture. ,

12.2.3 This warranty does not apply to:

(a) goods or components not manufactured by us. We will extend to you where possible the benefit of any guarantees, warranties or conditions if any, provided by the relevant manufacturer in respect of any such product or component (but subject to the same conditions and limitations) the cost of enforcing any such guarantee, warranty or condition to be borne by you; or

(b) any defective goods or components which have been repaired or modified without our prior written consent.

12.3 Warranty for Services

12.3.1 Unless otherwise required by law or stated in our quotation or agreed by us at the time of acceptance of your offer, subject to 12.4.2, the warranty period for the supply of services shall be three months from the date of completion of the service (Services Warranty Period).

12.3.2 We warrant that the services will be provided in accordance with the description contained within our quotation or the specification provided to you and that they will be provided with all due care and skill. However, except to the extent otherwise required by law, we will not be liable for any failure to provide the services as aforesaid unless you notify us in writing of your claim within the Services Warranty Period.

12.4 Warranty Conditions

12.4.1 If there is a breach by us of any warranty provided by us in regard to the Goods or services provided under this Agreement then we will:

(a) repair or replace the Goods or relevant parts;

(b) resupply or rectify the services; or

(c) where we determine that it is not feasible to repair or replace the Goods or rectify the services, refund to you of the amount invoiced for the Goods or services.

12.4.2 If you make a warranty claim in accordance with this clause 12, you will be responsible for all expenses associated with the warranty claim other than the costs of the repair, replacement, rectification, or refund for the Goods or services including the cost of returning any defective Goods to us.

12.4.3 The benefits to you of this express warranty are in addition to other rights and remedies you have under the Australian Consumer Law.

12.4.4 Our Goods come with guarantees that cannot be excluded under Australian Law. Subject to clause 13.2, where we breach a consumer guarantee under the Competition and Consumer Act

2010 you are entitled to a replacement or refund for a major failure and compensation for any other reasonably foreseeable loss or damage. You are also entitled to have the goods repaired or replaced if goods fail to be of acceptable quality and the failure does not amount to a major failure.

12.4.5 Second-hand equipment is not subject to warranty unless specifically stated in the quotation or agreed in writing at the time of acceptance of your offer.

12.4.6 All other terms, conditions, warranties, and guarantees implied or provided for by statute, common law or otherwise in relation to the Goods (including without limiting the generality of the foregoing any implied or imposed warranty or guarantee that the Goods are suitable or fit for any particular use or purpose or that the Goods will comply with a sample) or the services are hereby excluded, except for any warranties or guarantees which may not be excluded according to the applicable laws or regulations of a country which has proper jurisdiction.

12.5 Information

12.5.1 We do not warrant the accuracy, sufficiency, or completeness of any information provided by you. Liability for information provided by you remains the sole liability of you.