

SALAD & SANDWICH PREP TABLE

PREP TABLE



FSU-28

FSU-36

FSU-48



FSU-60

FSU-72

DRAWER MODELS



FEATURES

- Auto-closing doors & stopper
- Stainless steel finished front, sides and doors
- Stainless steel hood lid covers
- Locking dividers
- 244mm reversible cutting board

- PE coated sturdy wire shelves
- Rear-mount comperssor for enhanced airflow
- Airflow over the pans
- 5" casters (brakes at front)
- Accomocates 15cm deep pan (*pans are optional)

TEMPERATURE

- 0°C ~ 5°C

OPTIONAL MODELS

- Drawer model (custom-made)
- Drawer mixed model (custom-made)

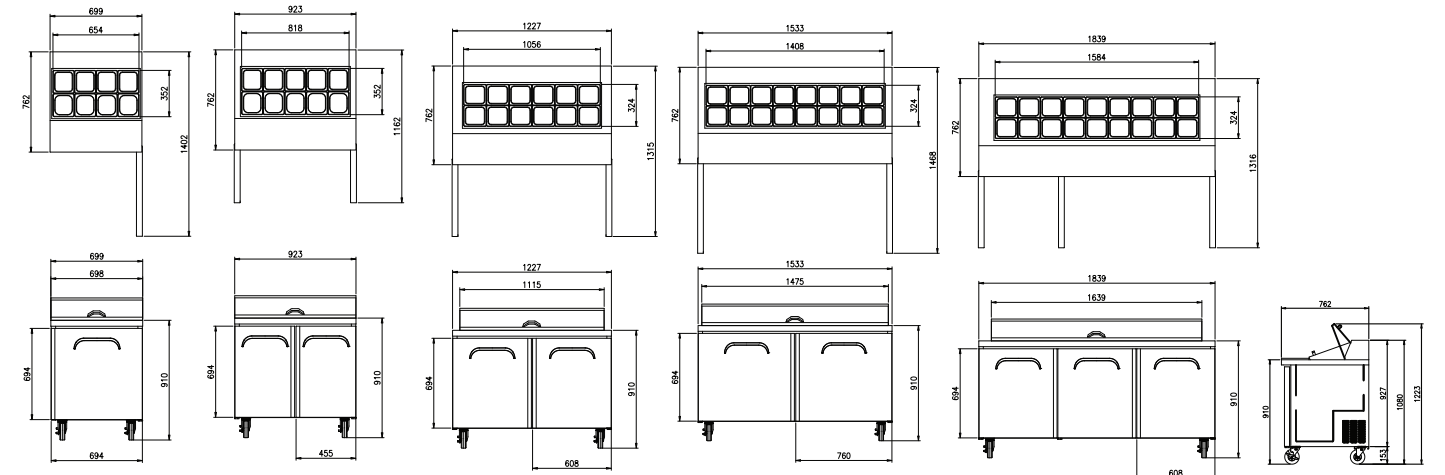

FSU-28

FSU-36

FSU-48

FSU-60

FSU-72

DRAWER MODELS

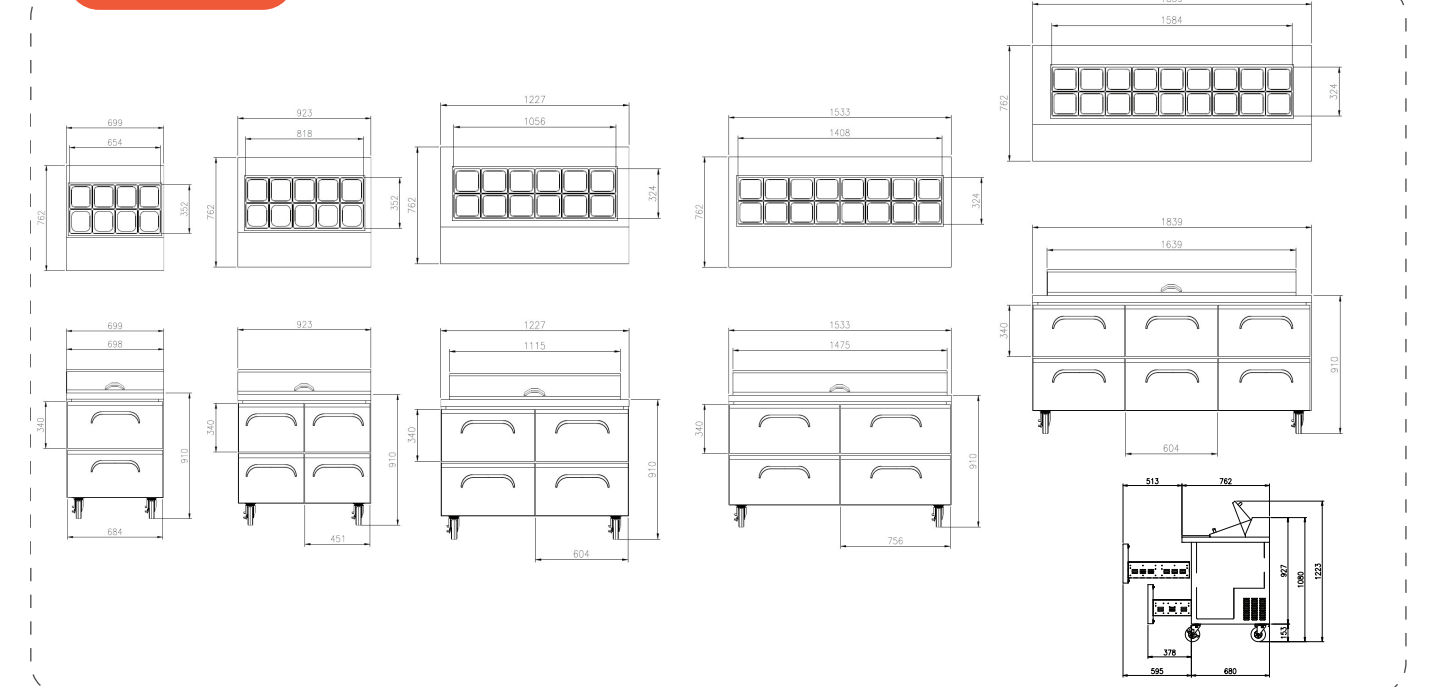

*The heights include the caster (128mm)

Model	Capacity (l)	Exterior Dimension (mm)			Net Weight (kg)	Gross Weight (kg)	Power Supply	Amps	Watt	HP	Refrigerant	No. Doors	No. Pans (1/6")
		W	D	H									
FSU-28	186	699	762	1,080	71	75	10A	2.0	320	1/5	R-134a	1	8
FSU-36	252	923	762	1,080	86	92	10A	2.0	320	1/5	R-134a	2	10
FSU-48	346	1,227	762	1,080	106	114	10A	3.2	340	3/8	R-134a	2	12
FSU-60	441	1,533	762	1,080	116	126	10A	3.2	340	3/8	R-134a	2	16
FSU-72	531	1,839	762	1,080	135	148	10A	3.2	340	3/8	R-134a	3	18
FSU-28-D2	186	699	762	1,080	85	89	10A	2.0	320	1/5	R-134a	2	8
FSU-36-D4	252	923	762	1,080	108	114	10A	2.0	320	1/5	R-134a	4	10
FSU-48-D4	346	1,227	762	1,080	132	140	10A	3.2	340	3/8	R-134a	4	12
FSU-60-D4	441	1,533	762	1,080	146	156	10A	3.2	340	3/8	R-134a	4	16
FSU-72-D6	531	1,839	762	1,080	175	188	10A	3.2	340	3/8	R-134a	6	18