

REFRIGERATION BAKERY CASE

FGR-12S

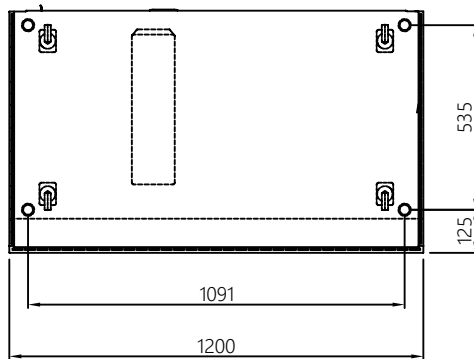
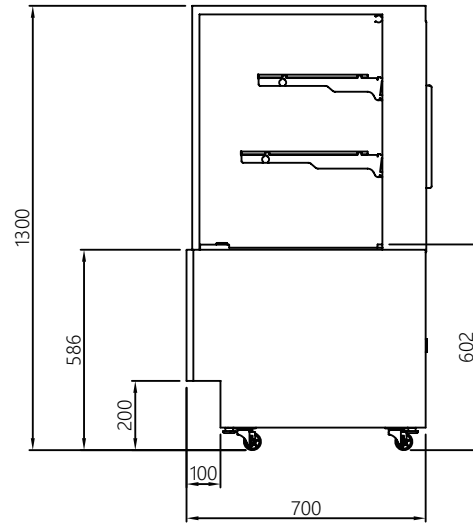
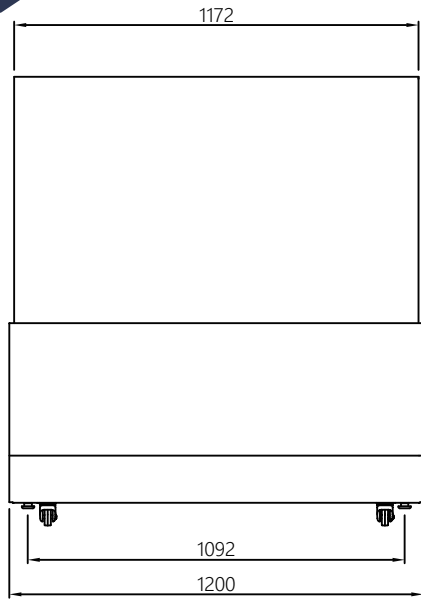

FEATURES

- Self contained system, no plumbing require
- Electronic temperature control
- Double pane glasses
- Water evaporatingsyste
- Alminum Rear Door & frame
- Stainless steel deck and air flow grille
- Straight, tempered front & side glass
- Minimal frame design for product display and visibility
- Caster (3")

TEMPERATURE

3°C ~ 7°C

OPTIONAL MODELS

- Leg

Model	Capacity (ℓ)	Exterior Dimension (mm)			Net Weight (kg)	Amps	Power Supply	Watt	HP	Refrigerant	Shelf
		W	D	H							
FGR-12S	405	1200	700	1300	175	4.3	10A	445	3/8	R-134a	1 deck + 2 shelves

* Exterior dimansions include 3" Leg height